

RAWNSLEY WOODLAND PRODUCTS

Shingle fixing instructions

Please note: only stainless steel nails (30mm Annular ring shank are ideal) should be used on our products, as Western Red Cedar is reactive with Iron, bright steel and galvanised fastenings.

Walls and vertical surfaces

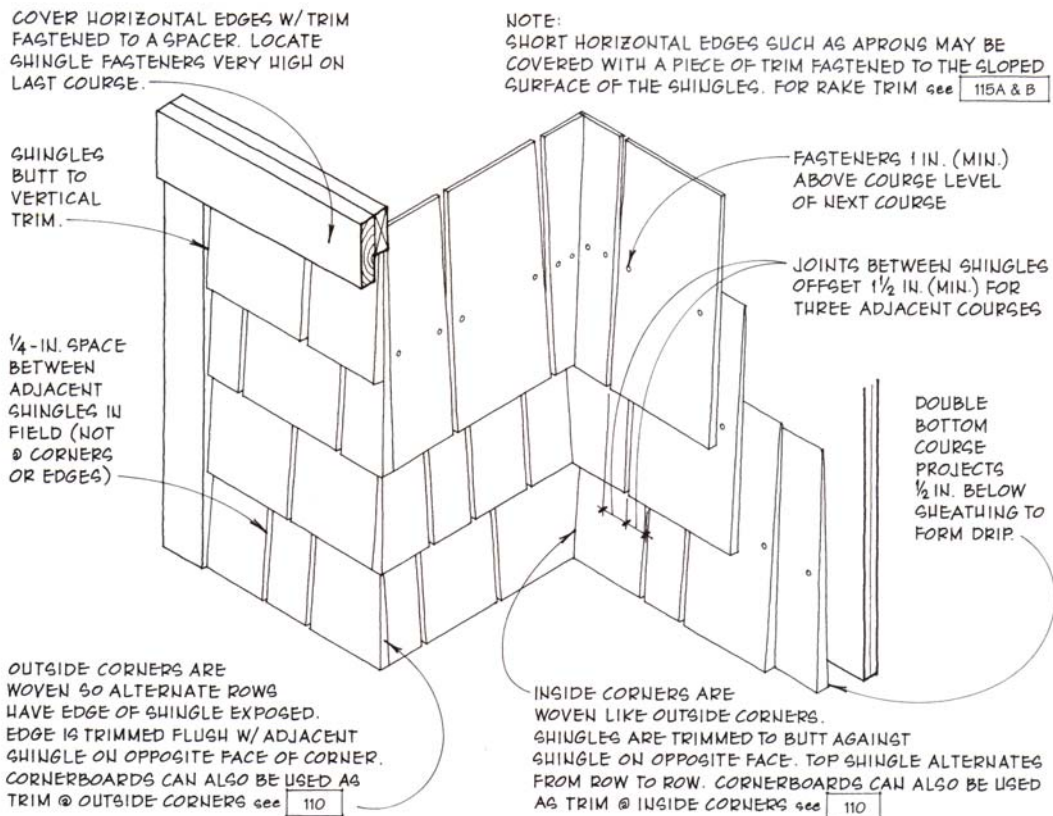

Roofs

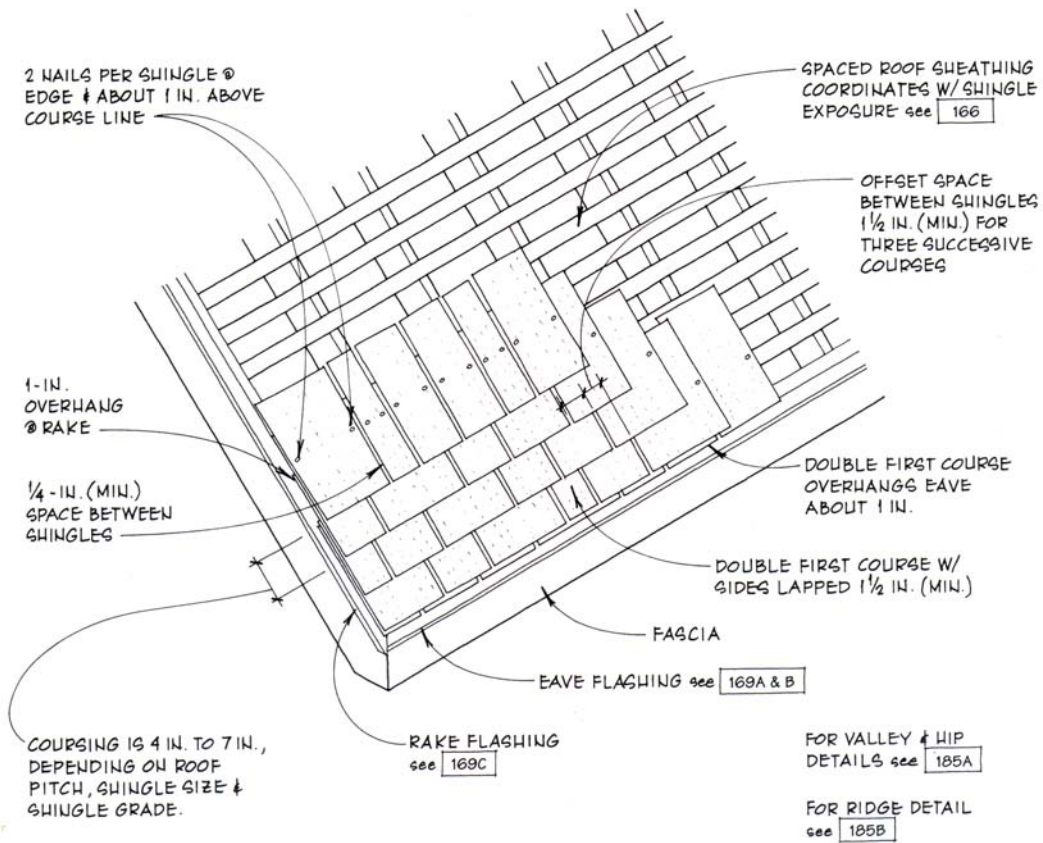

Hips and Valleys

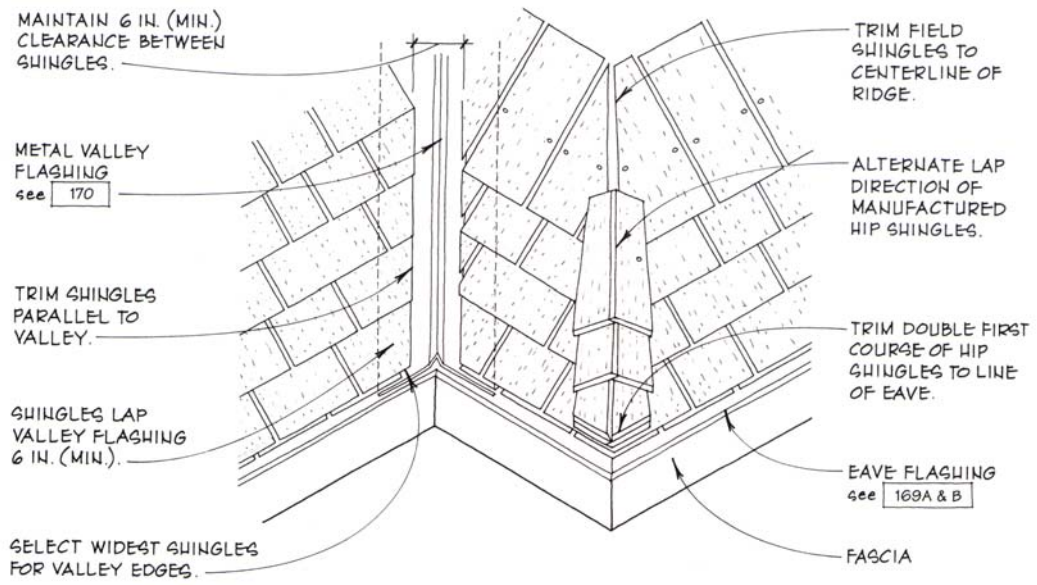

Ridges

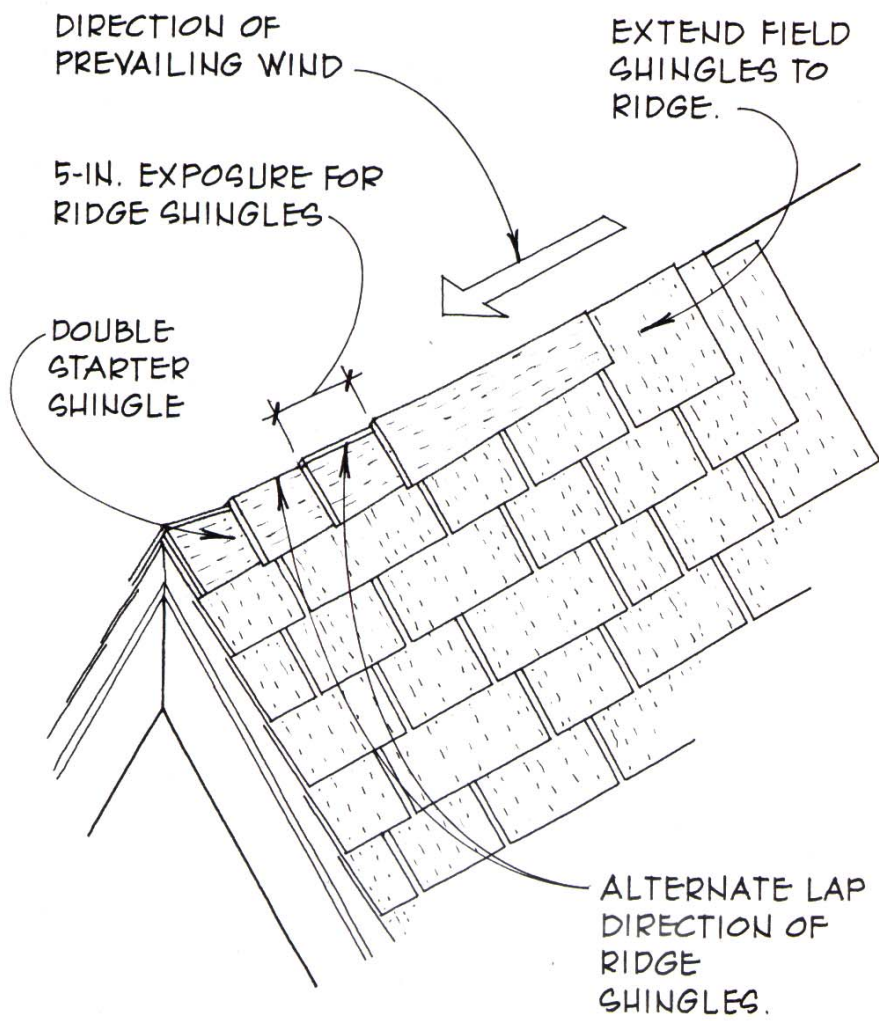

Gables

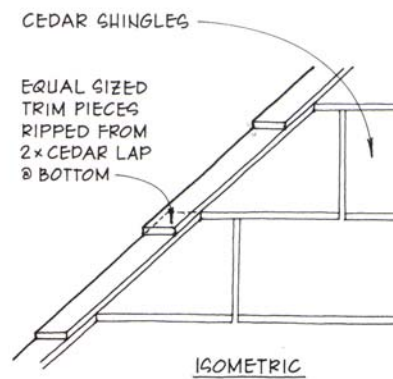
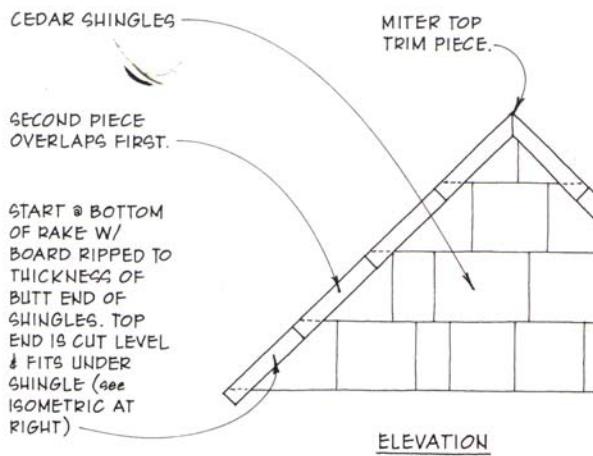

ONE METHOD OF FINISHING THE TOP EDGE OF A SHINGLE WALL IS TO LAP THE SHINGLE COURSES WITH TRIM PIECES RIPPED FROM A CEDAR 2x. IF THE COURSING IS EQUAL, ALL THE TRIM PIECES, EXCEPT FOR THE MITERED TOP PIECES, WILL ALSO BE EQUAL.

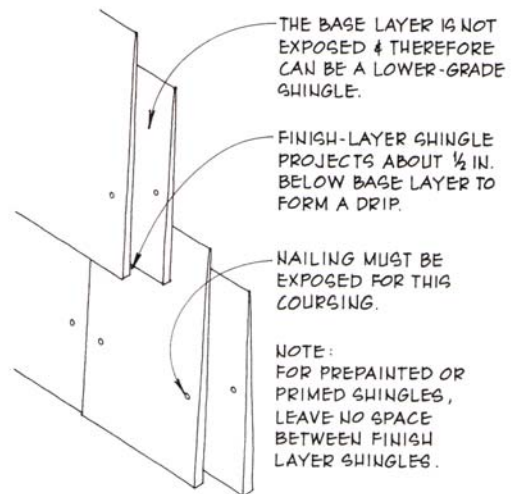
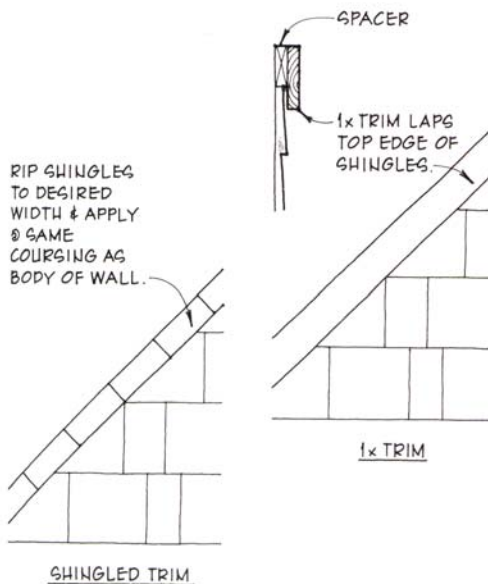

DOUBLE COURSING, AN ALTERNATIVE COURSING METHOD, CALLS FOR TWO LAYERS APPLIED @ THE SAME COURSE. A PREPAINTED OR PRIMED SHINGLE CALLED "SIDEWALL SHAKE" IS COMMONLY USED.